



Consortium
CONCORDE
Coastal River-Dominated Ecosystems

2015 CONCORDE is made possible by a grant from BP/The Gulf of Mexico Research Initiative (GoMRI)



- Background
- Field program information
- Examples of measurements
- Wind validation for synthetic modeling effort



How do complex fine-scale structure and processes in coastal waters dominated by pulsed-river plumes control the exposure, impacts, and ecosystem recovery from offshore spills like the Deepwater Horizon release of 2010?

Physical distribution and ultimate fate of contaminants associated with the Deepwater Horizon incident (Theme 1)

Environmental effects of the contaminants on Gulf of Mexico ecosystems, and the science of ecosystem recovery (Theme 3)



Objective 1: Characterize the distribution of planktonic organisms at relevant spatial and temporal scales as forced by the complex near shore physical environment and generating the setting for sub-surface ODS exposure.

Objective 2: Characterize the complex 4-D physical, geochemical, and bio-optical fields influenced by pulsed river discharge to characterize potential 3-D pathways of ODS to the coast, and mechanisms for enhanced interactions of ODS with plankton, suspended sediment and oil, which determine fate and toxic exposure, and informs synthetic biophysical-ecotoxicological models.

Objective 3: Generate a synthetic model that incorporates fine-scale 4-D biophysical processes that reveals exposure pathways reflective of DWH, and which will be portable to future spill scenarios impacting similar river-dominated coastal ecosystems.



Consortium
CONCORDE
 Coastal River-Dominated Ecosystems

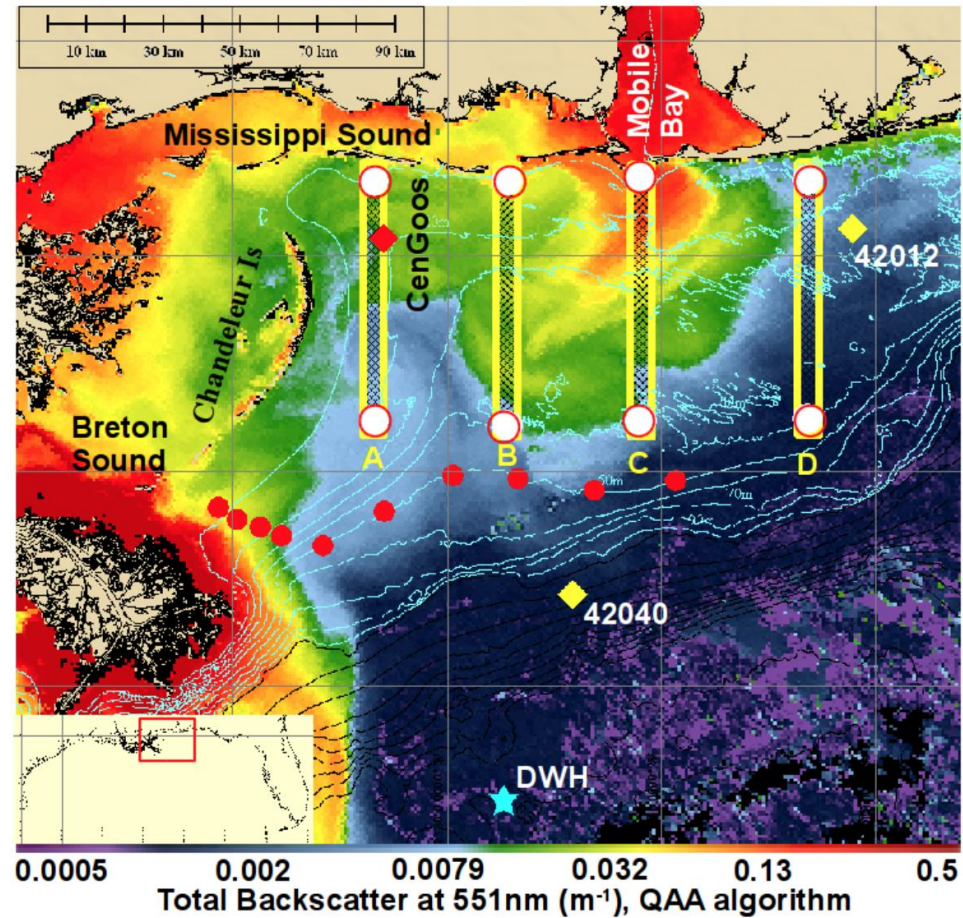
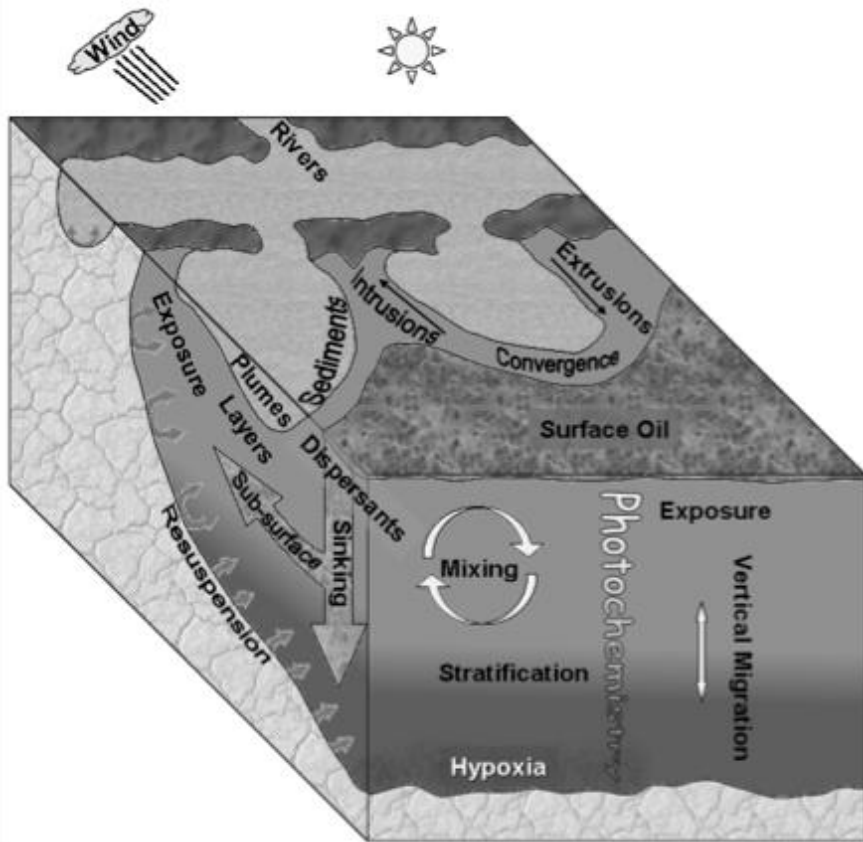

Field program information

• Objectives

- Relate distribution of plankton in nearshore habitats at relevant spatial and temporal scales to complex and dynamic physical forcings
- Understand exposure risk of planktonic community during an oiling event

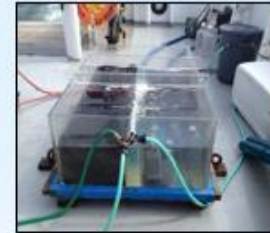

• Objectives and Methodology

Plankton Sampling Equipment

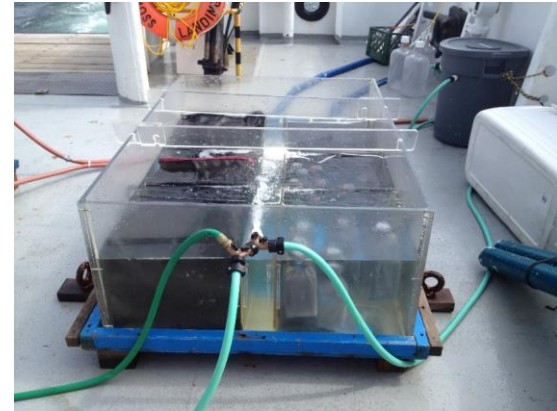
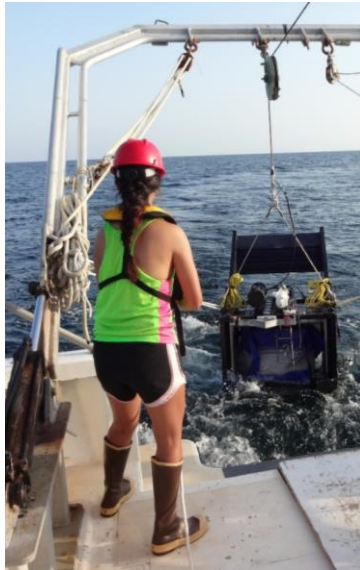
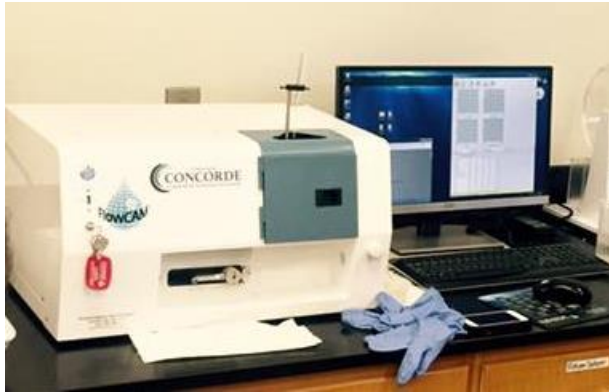
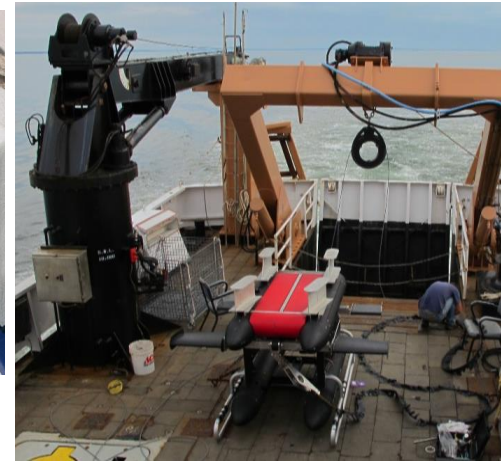
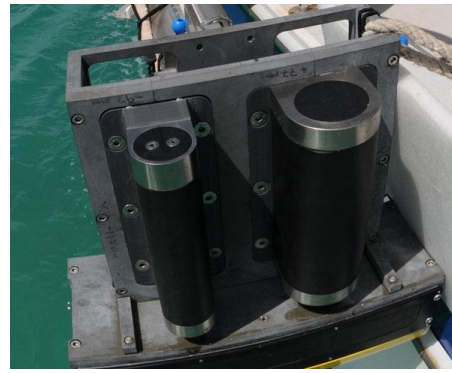
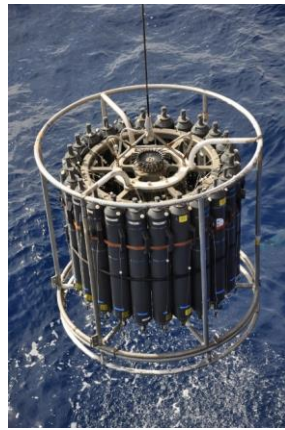

The plankton sub-project will be collecting zooplankton and ichthyoplankton samples using the MININESS and Neuston nets, image data using the DPI, acoustic backscatter data that further complements our plankton samples and DPI images. In addition, we are also using a FlowCam to identify phytoplankton and microzooplankton species.



all Field Campaign

Ocean Weather Lab

Deploy the “mixing array”

Additional met station on Ship Island

Small vessel surveys of barrier island passes to the

Mississippi Sound and Mobile Bay

Slocum glider deployment

R/V Pt Sur 24 October-7 November

R/V Pelican cruise 1-7 November

Objective 2:

Approach: Fall Field Campaign



Remote Sensing

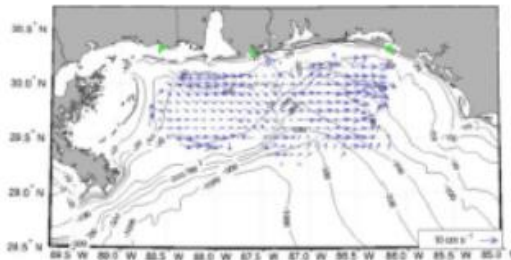
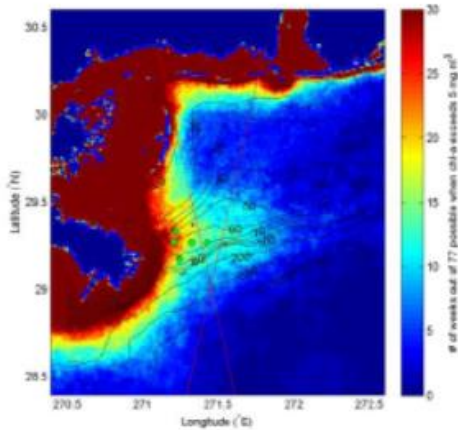

Operational Models

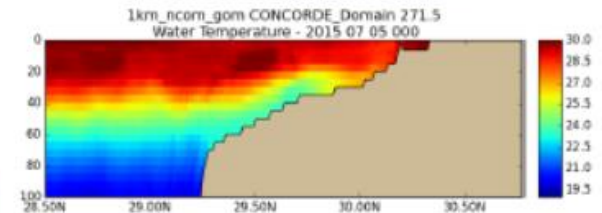
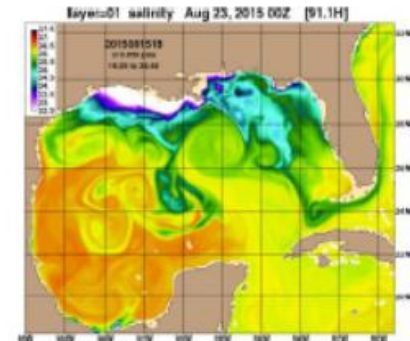

Moorings

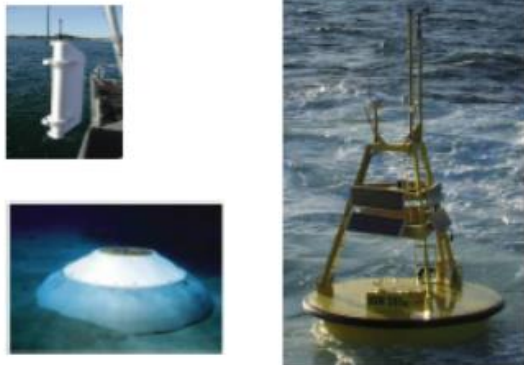

Adaptive Sampling

Gliders



Ship and Boat Surveys



- Water Column well-mixed during Fall Campaign (October 28th-November 2nd, 2015)
 - Preliminary examination of imagery data and plankton samples suggest biological structure present
- Collected
 - 143 depth-discrete plankton net samples
 - 42 hours of ISIS imagery
 - Analysis of 47 samples of size-fractionated N-15, C-14, biogenic silica, DIC, POC/N, and Silicon-32
 - 147 FlowCam samples

Mobile Bay Corridor- October 30, 2015

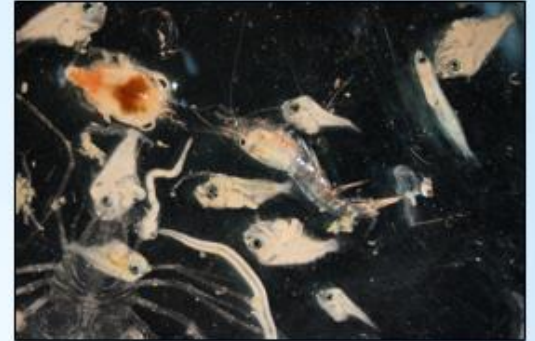

Eastern Corridor- October 31, 2015

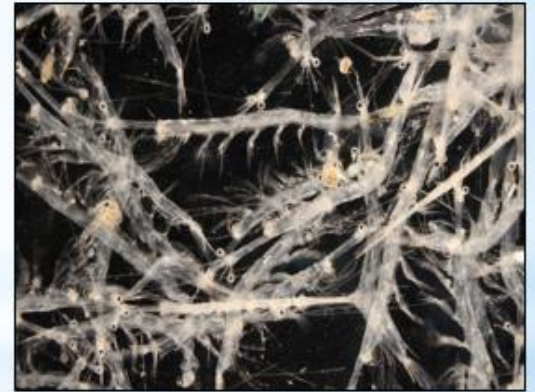

• Fall 2015 Cruise Accomplishments

Mixing was due to remnants of Patricia

ISIIS – In Situ Ichthyoplankton Imaging System

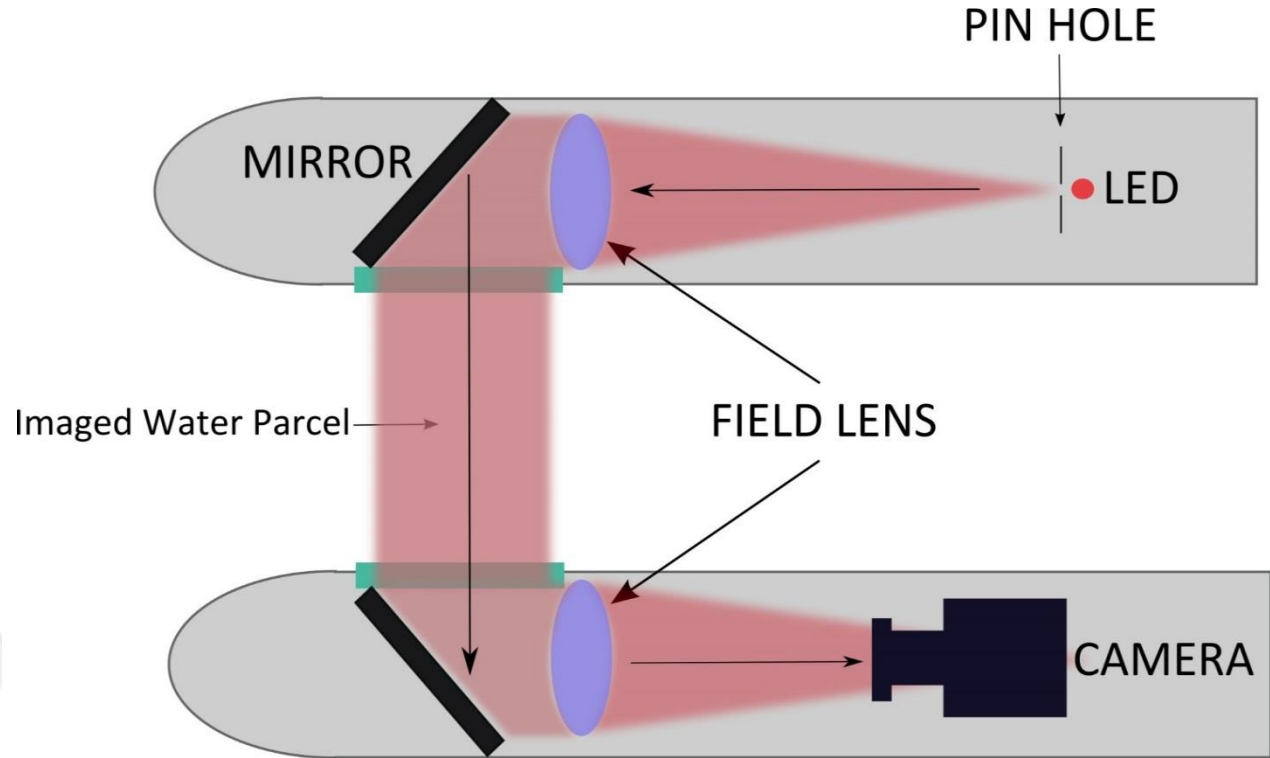

- Motor actuated wings
- Temp, salinity, PAR, chl-a, oxygen collected at 2 Hz
- 16-17 images per second (14 cm * 14 cm * 40 cm)
- 2 TB of image data every 3.5 hours

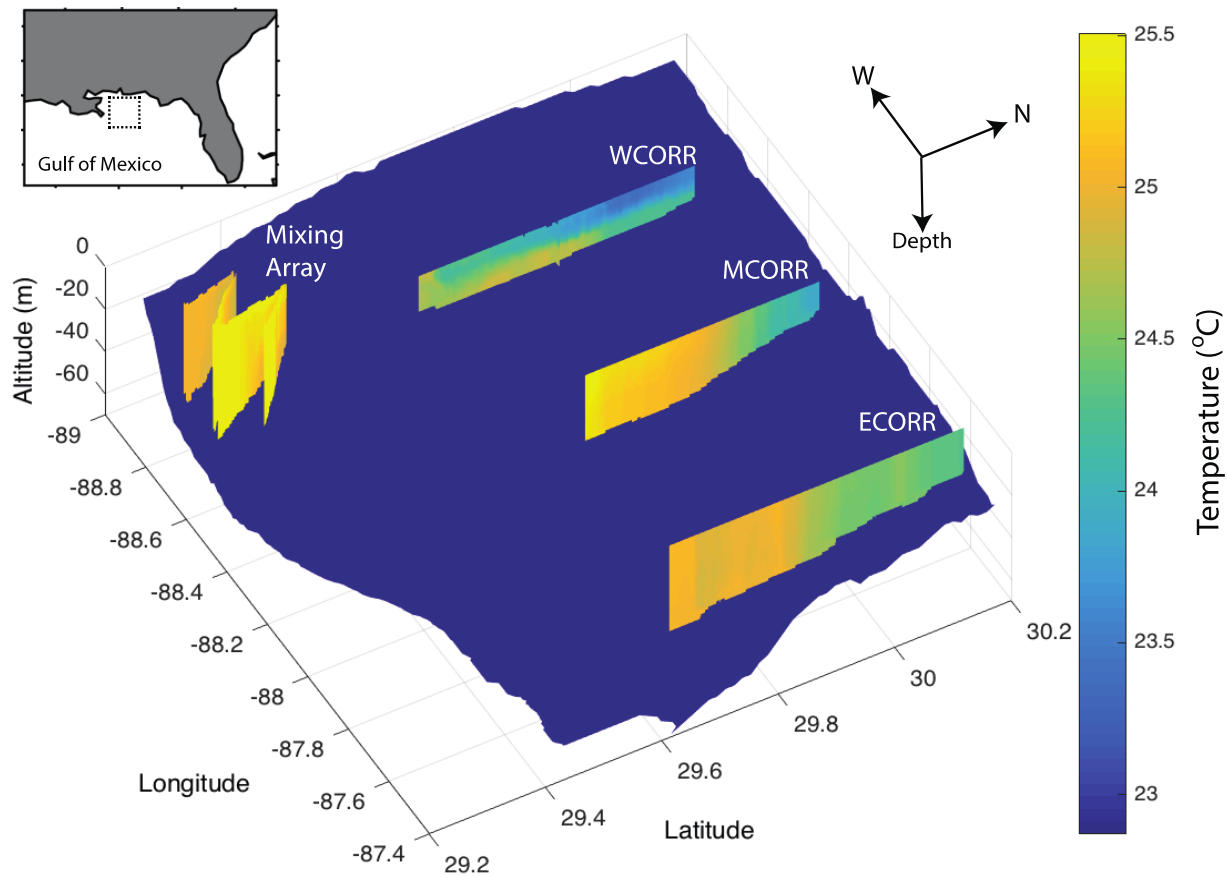

Temperature measured along 3 corridors with the In Situ Ichthyoplankton Imaging System (ISIS) (CTD attached to plankton imager)

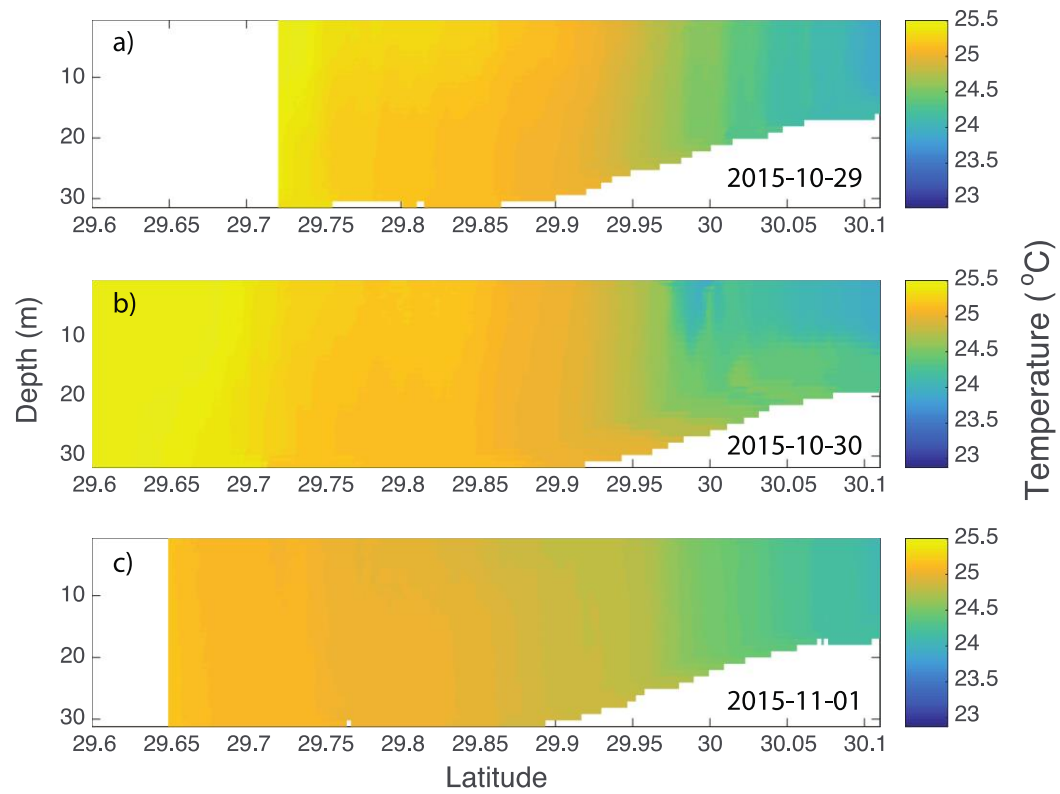

Temperature along the middle corridor for 3 sampling days

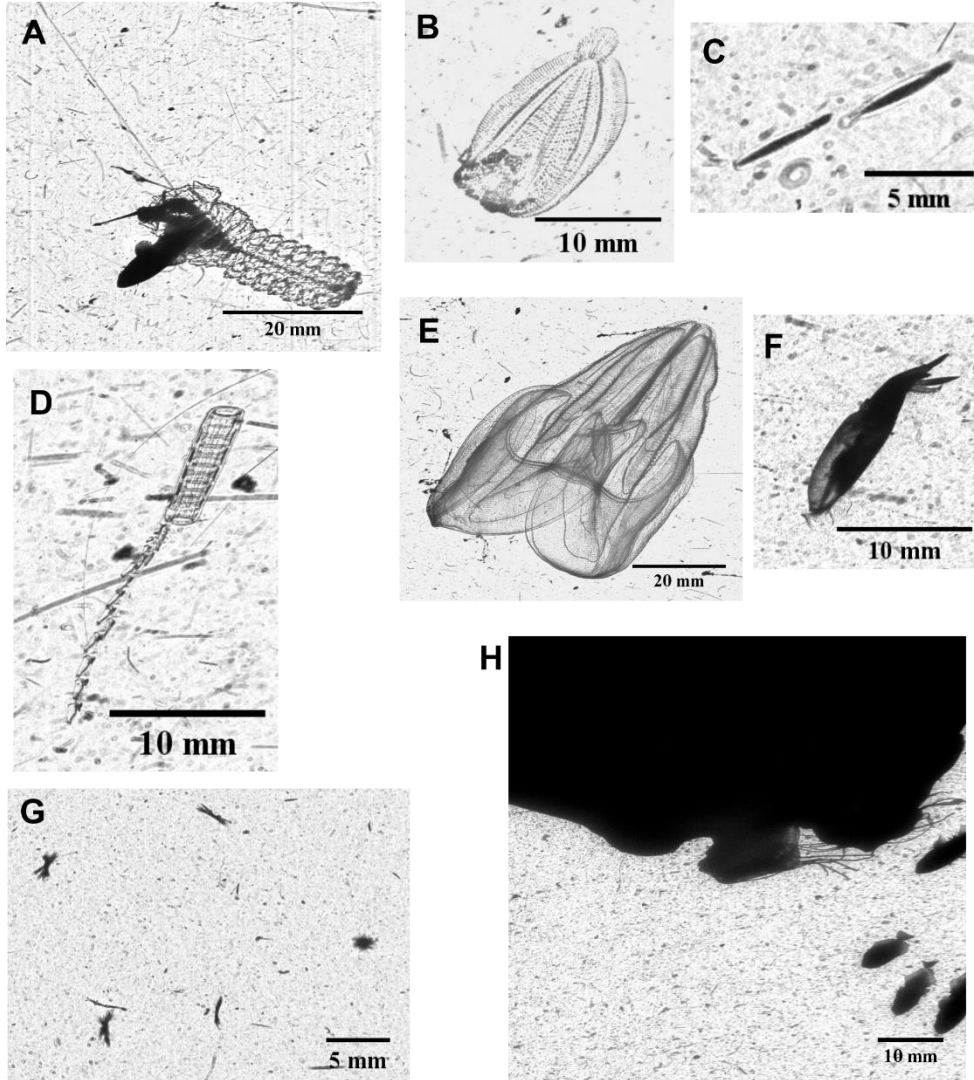

Example images captured with the ISiIS during the Concorde fall campaign a) siphonophore preying on a larval fish b) larval flatfish c) Two round herring larvae found in dense aggregations d) Doliolid e) Lobate ctenophore (*Mnemiopsis* spp.) f) larval squid g) trichodesmium h) larval jacks near the bell of a large *Aurelia* spp. jellyfish

Zooplankton captured
with the plankton nets
to compare to image
data

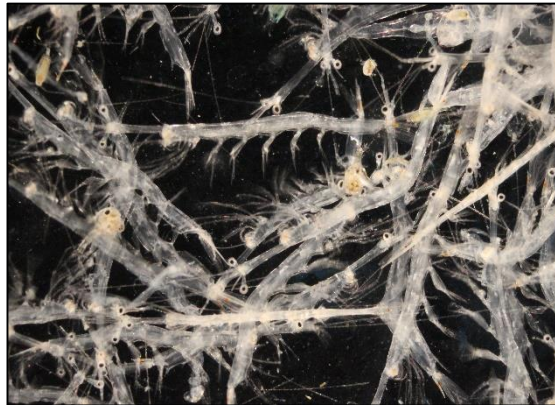
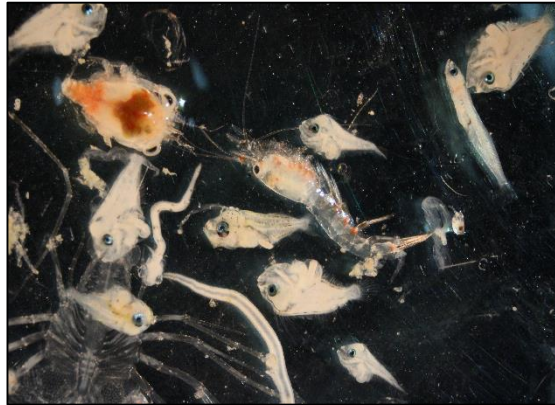
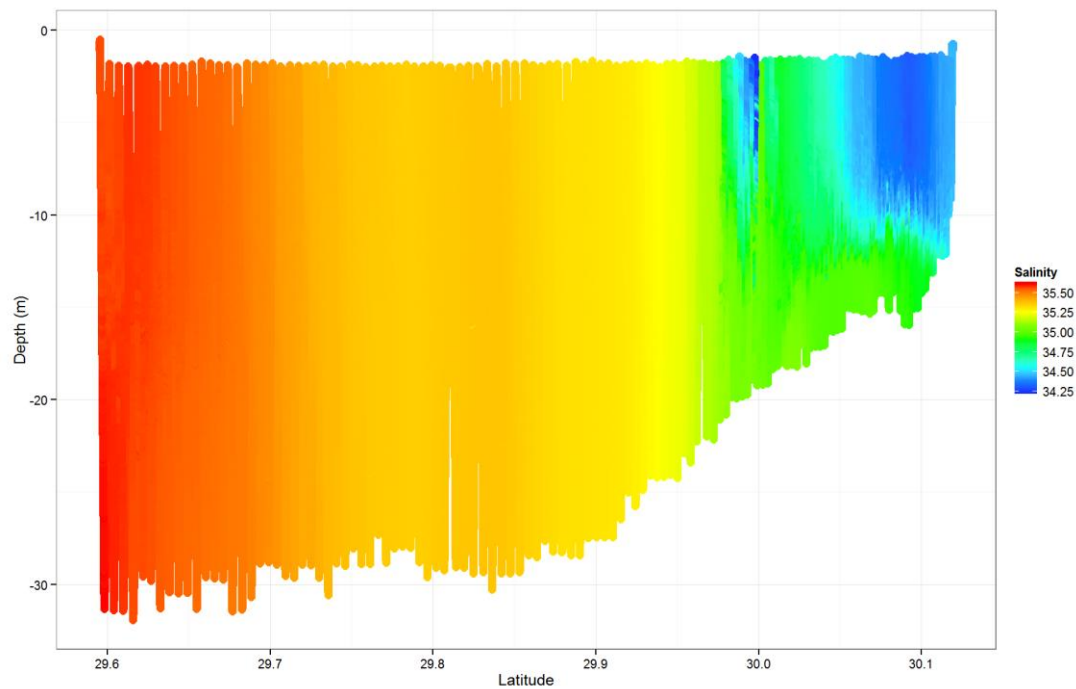
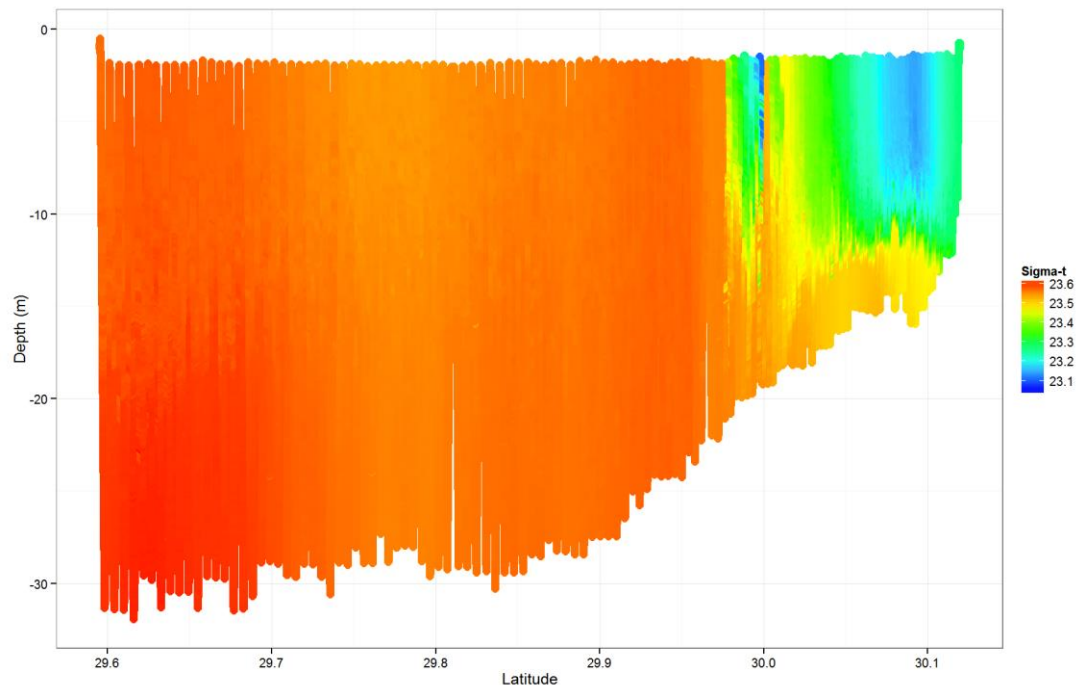
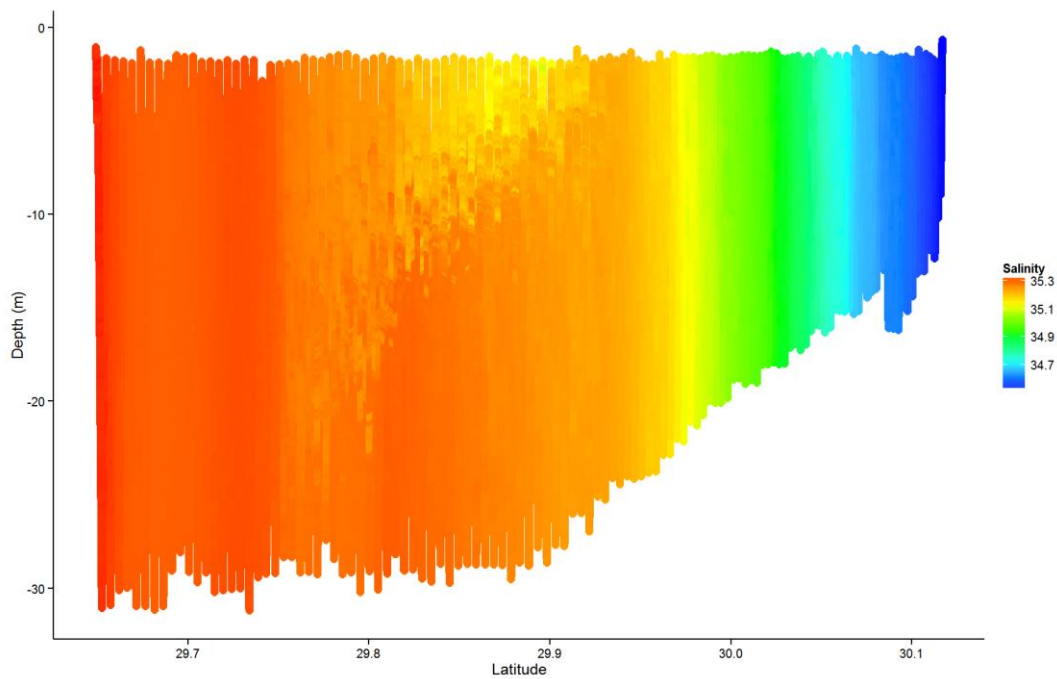
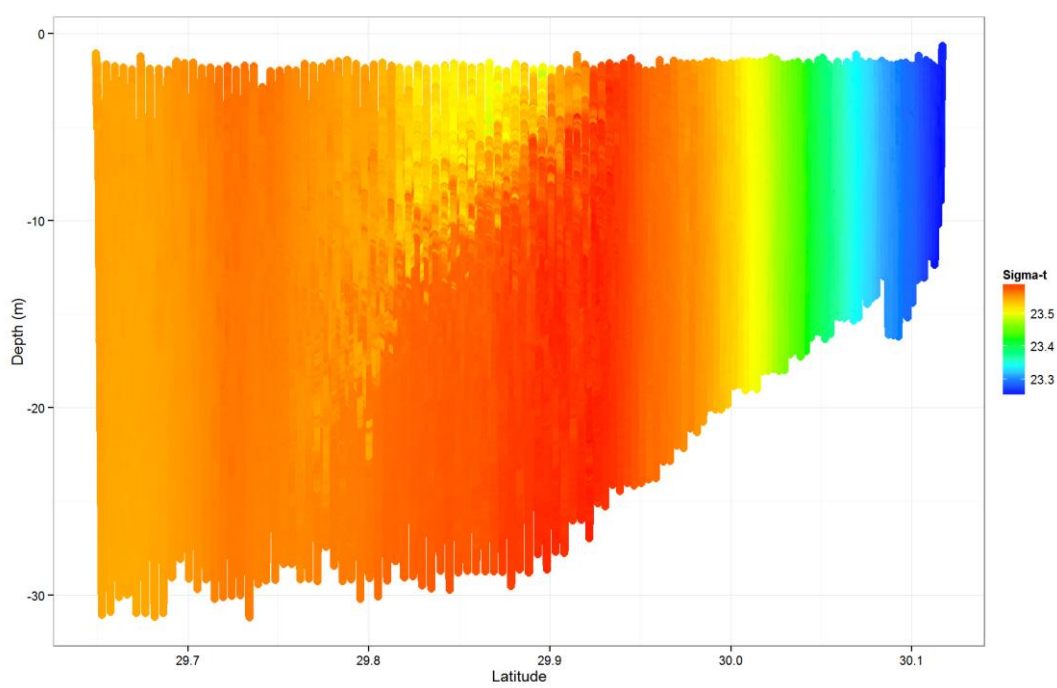

Figure 1. Images of plankton from
corridor sampling region from Mobile
corridor (top) on October 30th to the
Eastern corridor (bottom) on October
31st. Photo credits: Hernandez lab.

Salinity
and
Sigma-t
from
middle
corridor
on Oct 30
2015



Salinity and
Sigma-t from
middle corridor
on Nov 1 2015



Ocean Weather Laboratory: Daily Now Cast

Circulation Models, Satellite Bio-optics, *In situ* data



Ocean Weather

<http://www.usm.edu/marine/research-owx>

VIIRS Chlorophyll-a, NCOM Current Vectors and Surface Salinity Contours: November 1st, 2015

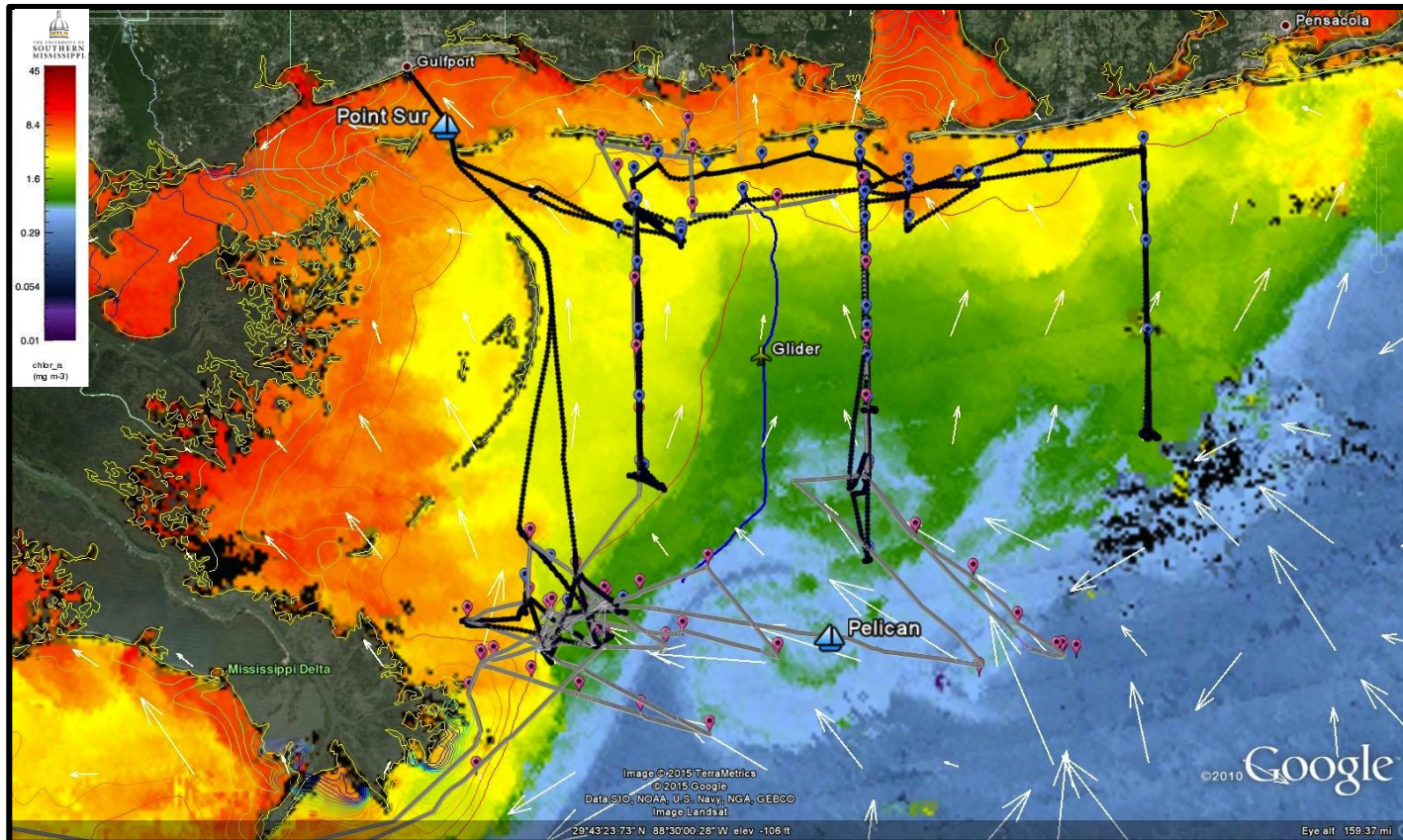

Fall Cruise Tracks
Point Sur
Pelican
Glider

The Ocean Weather Lab provided daily satellite and modeled ocean data to assist with strategic cruise planning, glider deployment, and sampling locations.

Ocean Weather Laboratory: Daily Now Cast



Satellite Products

- Chlorophyll-a
- Light Attenuation
- Particles
- Sea Surface Temperature
- Phytoplankton and CDOM Absorption

High Resolution Model Products

- Current Vectors and Magnitude
- Sea Surface Salinity
- Sea Surface Temperature
- Mixed Layer Depth
- Sea Surface Height
- Regional cross sections

In situ Field Work

- Inherent and apparent optical properties

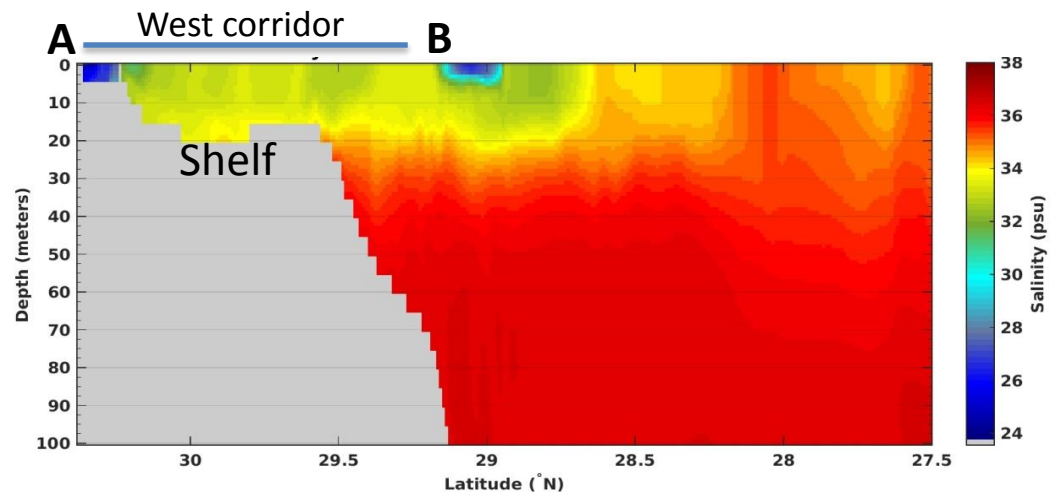
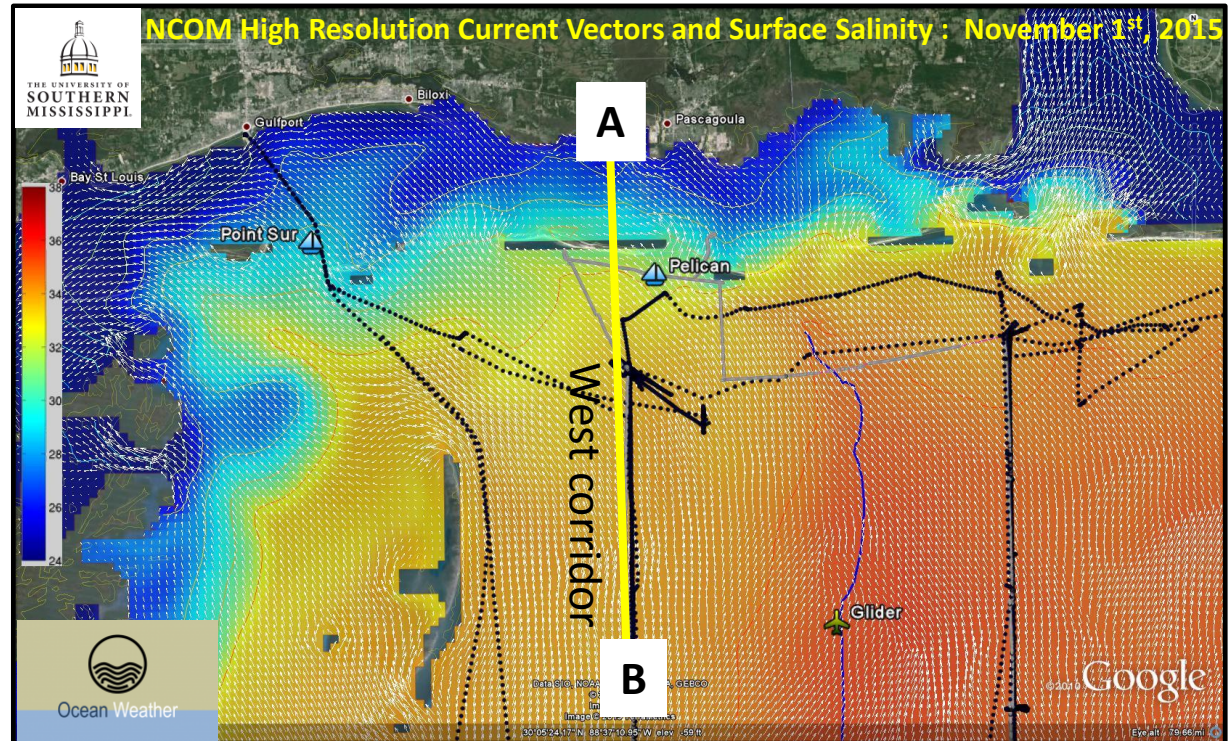

Objective 3 – synthetic modeling effort

Synthetic Model Objectives

- Gain mechanistic understanding of the interlinked physical and biogeochemical processes within the MS Bight
- Targeted Foci of MS Bight Biophysical Complexity
 - Surface and sub-surface advective exchanges across the shelf break of the MS Bight
 - Spatio-temporal patterns of marine planktonic distributions that can be exposed to crude oil toxins when spill events occur
 - Inherent physical or geochemical mechanisms that may protect the nearshore waters of MS Sound from toxicological exposure

Overarching Motivations:

- 1) Provide the means to explore and assess these toxicological, hydrodynamic and geochemical influences and their variability
- 2) Evaluate mitigation strategies that seek to prevent oil spill exposure of sensitive coastal marine ecosystems, fisheries and recreational areas

Components of Synthetic Model Effort

- **MSU Atmospheric Reanalysis Product**
 - Source of surface boundary conditions (Resolution: 1 km, Hourly)
 - Capture wind events (e.g., storm fronts, cyclones) that raise water levels and create inshore currents in shallow coastal waters
 - Capture the diurnal sea-breeze Synthetic Model
- **NRL Operational Model of the Gulf of Mexico**
 - Source of outer boundary condition forcing along southern and eastern domain boundaries (Resolution: 1 km, 3 hourly)
 - Critical for informing the synthetic model about cross-shelf advective exchanges, in particular episodic sub-surface intrusions (Sub-group 2)
- **ROMS-based application with fully coupled biogeochemical/ lower trophic level model**
 - The synthetic model will integrate the forcing and knowledge derived from these two stand-alone modeling components

Atmospheric Reanalysis Development

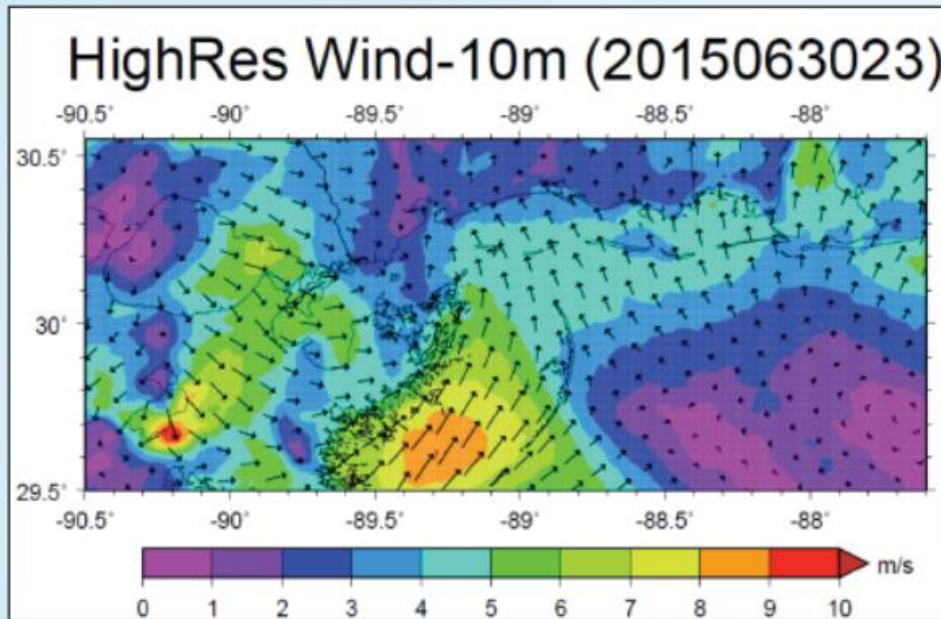

- 3DVAR, OI, Cressman, Barnes reanalysis code prepared
 - Sensitivity tests underway
- Hourly wind analyses from NOAA's Real-Time Mesoscale Analysis (RTMA) online at MSU
 - These are being transitioned to CONCORDE website
- Scripts to generate 1-km atmospheric forcing for three-year ROMS runs completed
 - Transitioned to USM computers
 - Needs testing with ROMS Application

• Data Sources

- Model data is provided by NOAA's Operational Model Archive and Distribution System (NOMADS)
- Radar data is provided by NOAA's Hierarchical Data Storage System (HDSS)
- High-resolution AVHRR SST data is provided by NOAA's Atlantic Oceanographic & Meteorological Laboratory (AOML)
- FSU's COARE flux algorithm 3.0 is applied as necessary for consistency with NRL's COAMPS

WeatherFlow Platform

(Diurnal Winds Assessment in MS Sound)

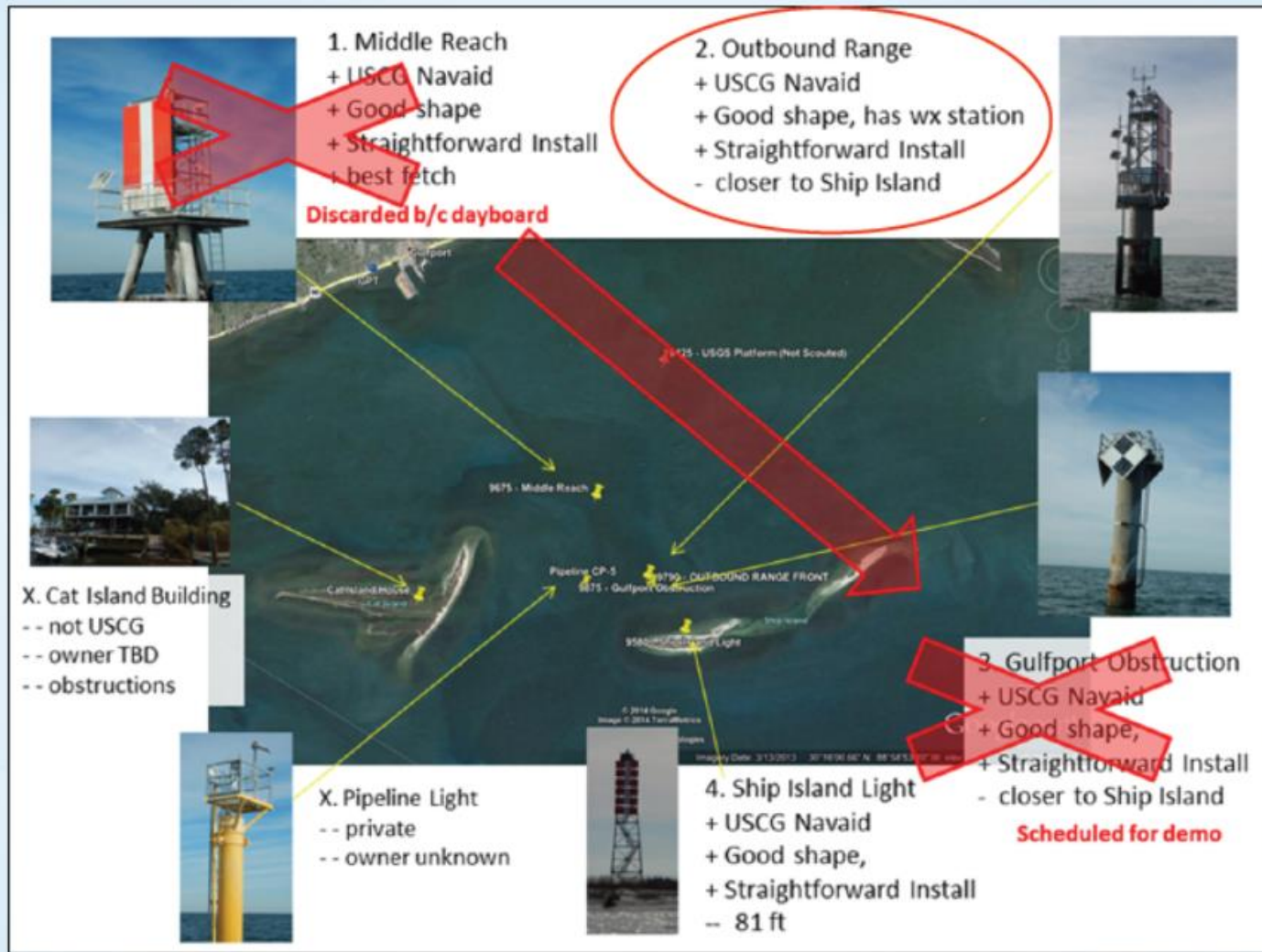

Awaiting Coast Guard Approval

CONCORDE All Hands Meeting: 9 - 10 September 2015

Outer Boundary Conditions

NRL Model: Surface Temperature & Currents

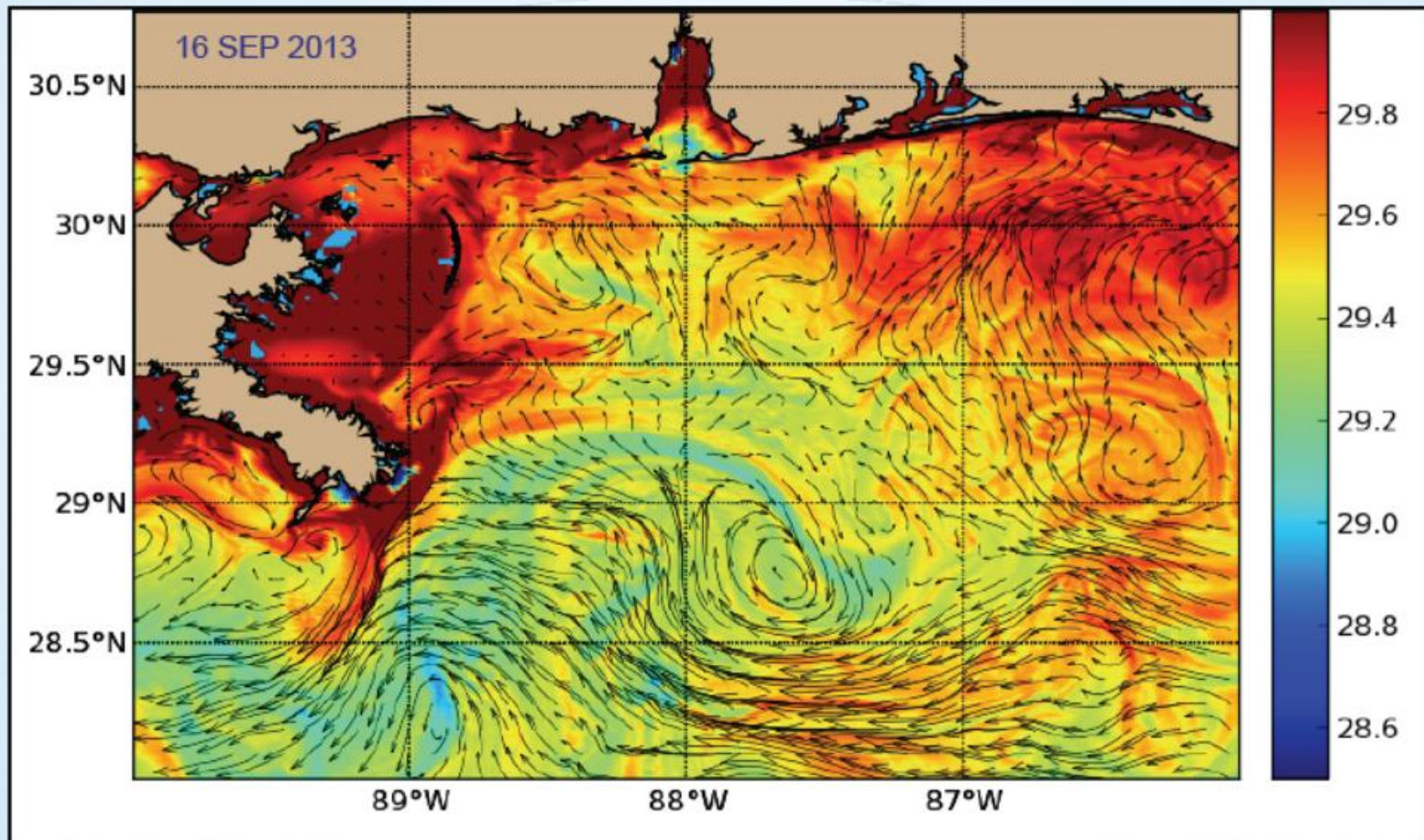

Salinity Evolution on MS Bight: Shelf Connection

(Analysis in progress: Jacobs, Arnone et al.)

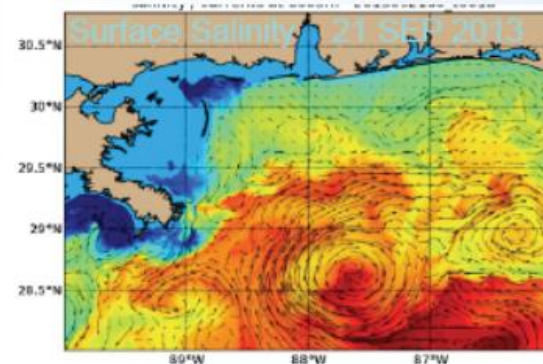
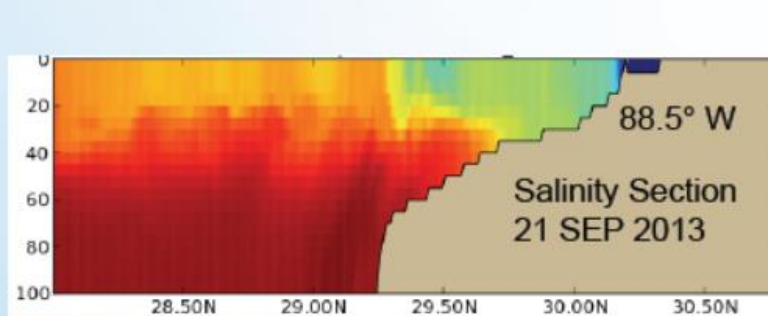
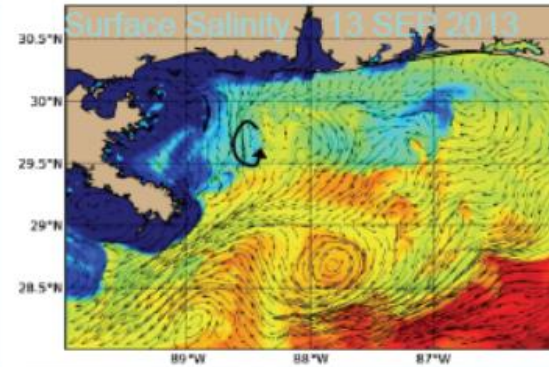
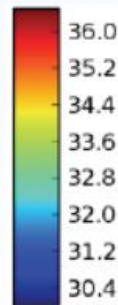
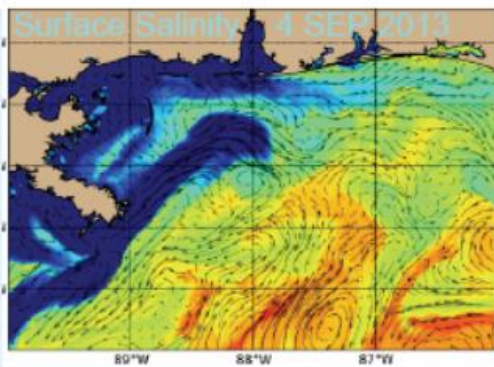
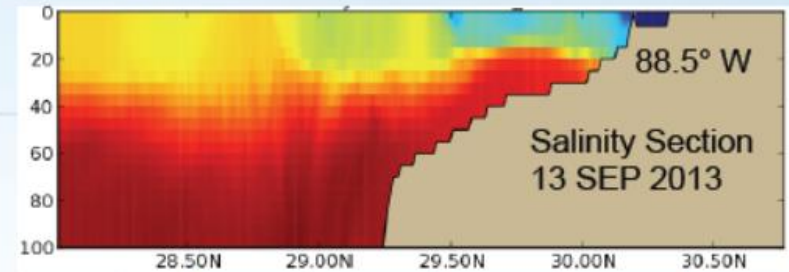
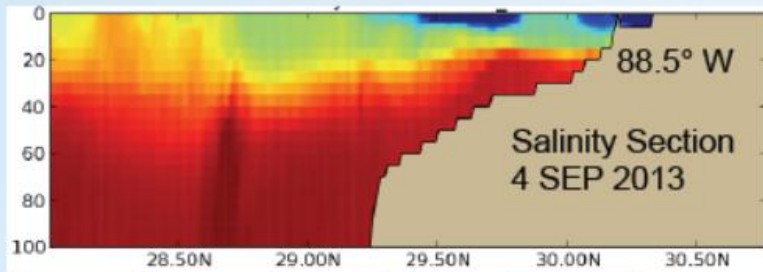

Salinity Evolution on MS Bight: MS Sound Connection (Remote Sensing Bio-optics -> Salinity Proxy)

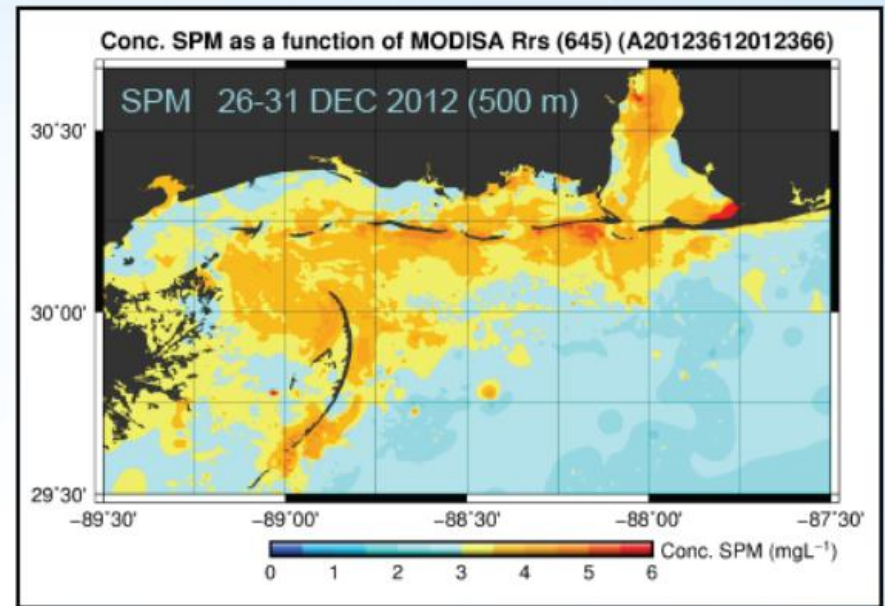

Sediment loadings indicated in these graphics are a critical aspect of the bio-optical variability that is essential to capture for fidelity of the model ecosystem

MODIS and MERIS Level 1 data are being processed to develop insight into spatio-temporal variability of sediment plumes in coastal / shelf waters

Key concern is to accurately simulate the in water light field for model ecosystem

Bathymetry & Domain of Synthetic Model

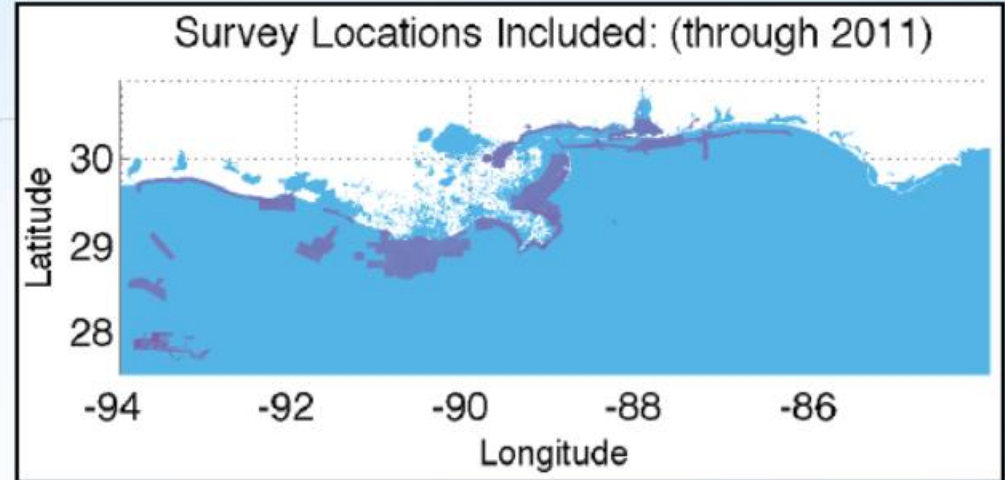
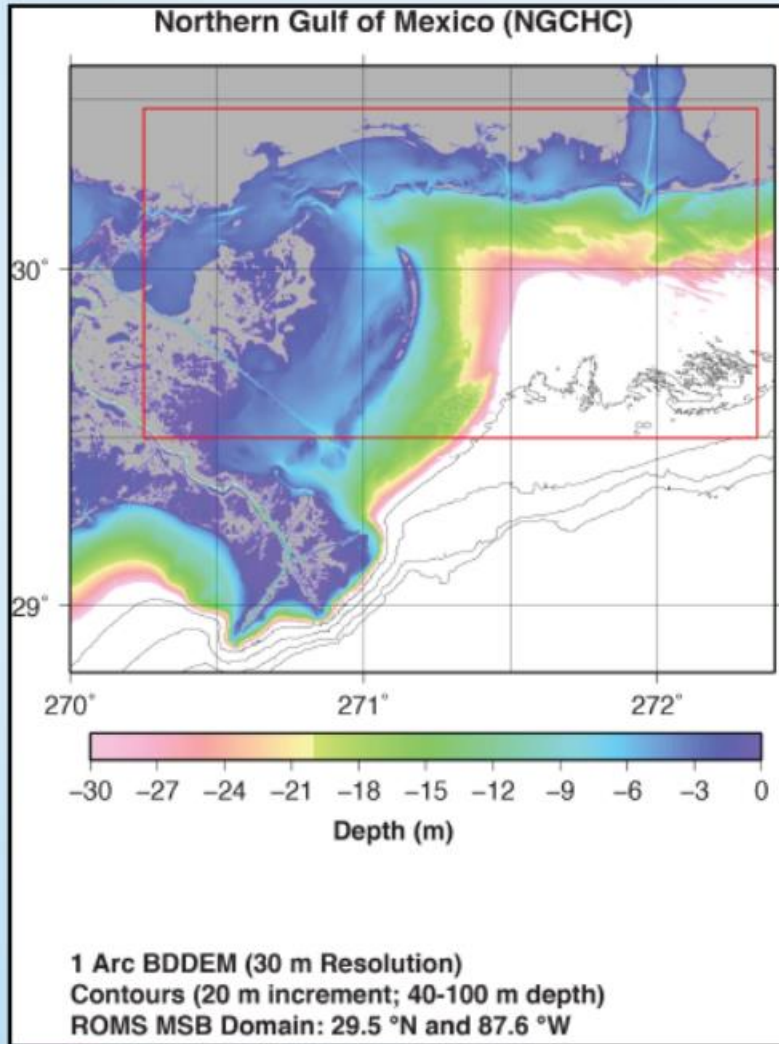

- Domain bathymetry shows shelf break, MS Bight and MS Sound
- Bathymetry model was updated through 2011 NOS surveys
 - Survey domains are shown in upper graphic
 - 3, 1 and 1/3 Arc bathymetry models were generated and available from USM - DMS THREDDS Server
- Outcome of an NSF EPSCOR-funded project

Biogeochemical Model

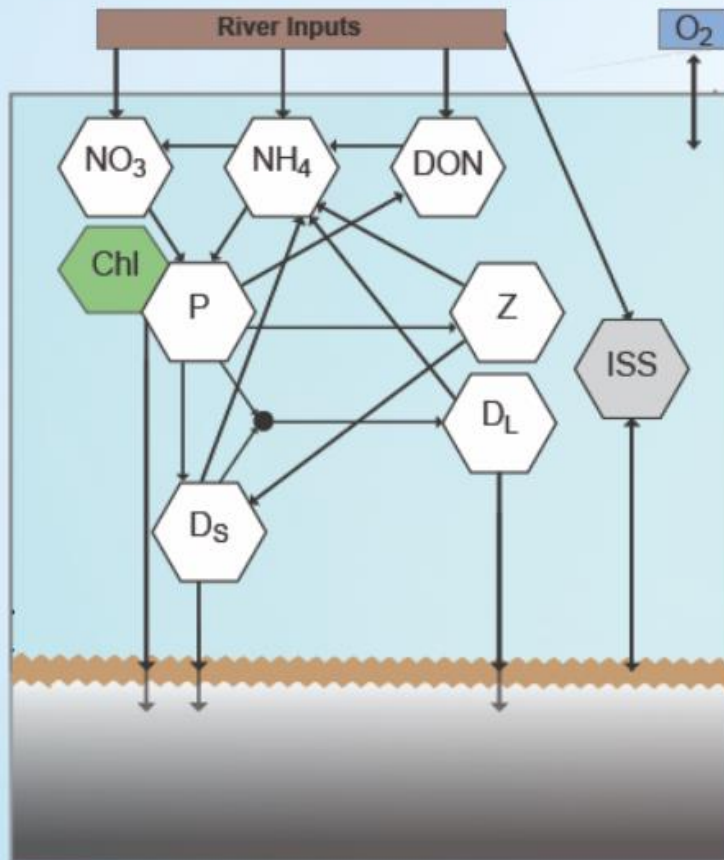

- Considerations & Sub-Group Links
 - P size partition data (J. Krauss)
 - 2 Phytoplankton Size Classes
 - Nutrients (J. Krauss)
 - Bottom Sediment Type (I. Church)
 - Sediment Resuspension
 - LISST and SPM Observations
 - Light Attenuation
 - Spatio-temporal Plankton Distributions from DPI
 - Patterns with environmental context (mixing, bio-optical setting)
 - Nutrient Source (A. Shiller)
 - Nutrient Delivery Path to Inner Shelf

RTMA Validation

See talk at 4:30PM

Room 342

Observations used for validation



- Used nearest neighbor RTMA with most appropriate land cover
- Wind observations converted to 10-meter height (when possible) and 1-minute average (when possible)
- Future data will include WeatherFlow network (new platform installed at Ship Island, funded by CONCORDE)

Temperature (C)							Sample size		
Station	May 2015		Aug 2015		Oct 2015		May	Aug	Oct
	<i>Bias</i>	<i>Abs Err</i>	<i>Bias</i>	<i>Abs Err</i>	<i>Bias</i>	<i>Abs Err</i>			
KMSY	-0.8	0.8	-0.4	0.7	-0.6	0.7	191	167	166
BBNL1	0.0	0.5	0.0	1.1	0.1	1.3	190	168	164
D6246	0.1	0.5	0.5	0.8	0.4	1.0	191	167	151
SHBL1	-0.1	0.4	-0.6	0.7	-0.7	0.9	12	8	111
NNHM6	-0.2	0.7	0.3	1.1	-0.1	1.2	187	168	167
KGPT	-0.5	0.6	-0.6	0.8	-0.5	0.8	191	168	167
42067	0.2	0.5	-0.2	0.5	NA	NA	47	53	NA
PTBM6	-1.7	1.9	-0.5	0.8	-0.1	0.8	191	168	167
DPIA1	-0.4	0.5	-0.2	0.4	0.1	0.4	178	168	166

Wind speed (ms^{-1})							Sample size		
Station	May 2015		Aug 2015		Oct 2015		May n	Aug n	Oct n
	<i>Bias</i>	<i>Abs Err</i>	<i>Bias</i>	<i>Abs Err</i>	<i>Bias</i>	<i>Abs Err</i>			
KMSY	-1.9	1.9	-2.1	2.1	-1.7	1.7	187	157	154
BBNL1	0.6	0.8	0.0	0.7	0.0	0.5	188	115	114
D6246	1.6	1.9	0.4	1.2	0.5	1.2	164	161	150
SHBL1	-0.2	0.9	0.1	1.0	-0.7	1.2	164	155	140
NNHM6	1.1	1.2	1.2	1.3	1.1	1.2	170	118	115
KGPT	-2.2	2.2	-0.8	1.0	-2.1	2.1	171	135	130
42067	-0.6	1.3	-0.9	1.5	-0.1	1.1	46	53	13
PTBM6	0.2	1.2	-0.6	1.1	0.1	1.1	189	166	167
DPIA1	-0.1	1.0	0.7	1.5	-0.2	0.9	188	167	165

Wind direction (deg)							Sample size		
Station	May 2015		Aug 2015		Oct 2015		May n	Aug n	Oct n
	<i>Bias</i>	<i>Abs Err</i>	<i>Bias</i>	<i>Abs Err</i>	<i>Bias</i>	<i>Abs Err</i>			
KMSY	-3,7	12.0	-2.8	20.7	-3.0	18.2	185	155	151
BBNL1	20.6	24.7	15.3	32.8	23.7	32.5	188	115	114
D6246	12.5	14.0	2.4	25.6	6.2	21.3	164	161	150
SHBL1	7.1	10.7	14.7	29.3	2.6	16.3	164	155	140
NNHM6	14.8	17.9	-1.6	33.1	11.8	24.6	170	118	115
KGPT	4.4	9.1	-4.2	17.3	-0.3	14.4	169	128	127
42067	-2.7	10.4	-6.2	24.1	3.9	15.8	46	53	13
PTBM6	7.5	12.3	-8.7	22.8	6.2	14.7	189	166	167
DPIA1	4.8	12.4	8.2	21.3	9.3	14.4	188	167	165

RTMA comparison to observations match well, but there are outflow boundary issues

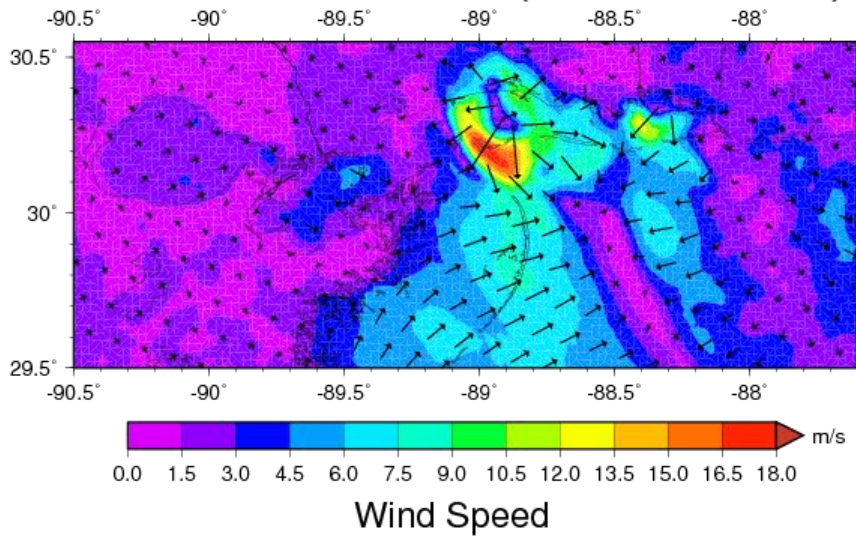
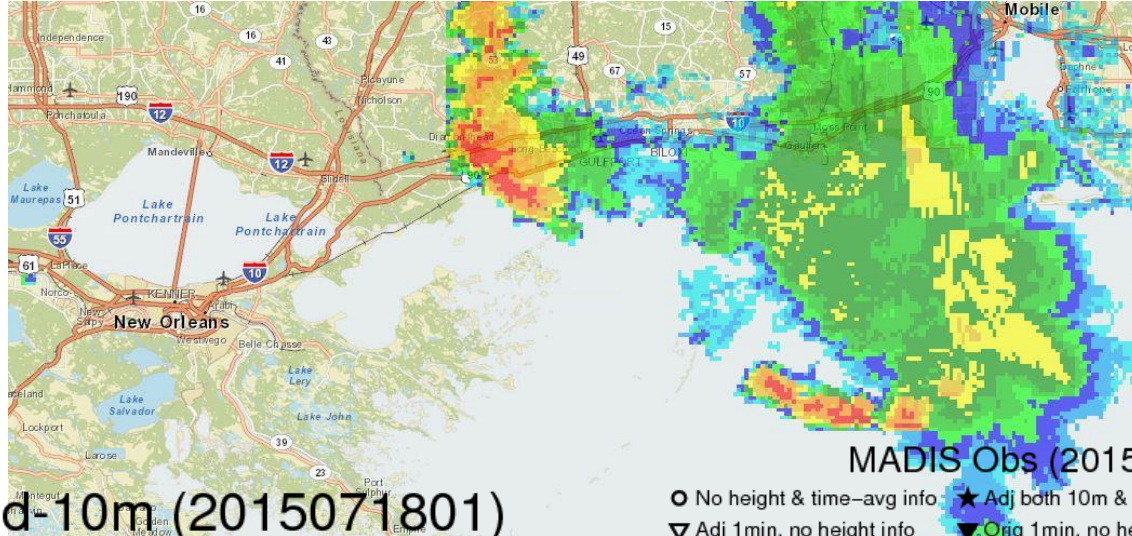

MADIS Obs (2015071801)

- No height & time-avg info ★ Adj both 10m & 1min × Orig 10m & 1min
- ▽ Adj 1min, no height info ▼ Orig 1min, no height info ■ Orig 1min, adj 10m
- △ Adj 10m, no time-avg info ▲ Orig 10m, no time-avg info ◆ Orig 10m, adj 1min

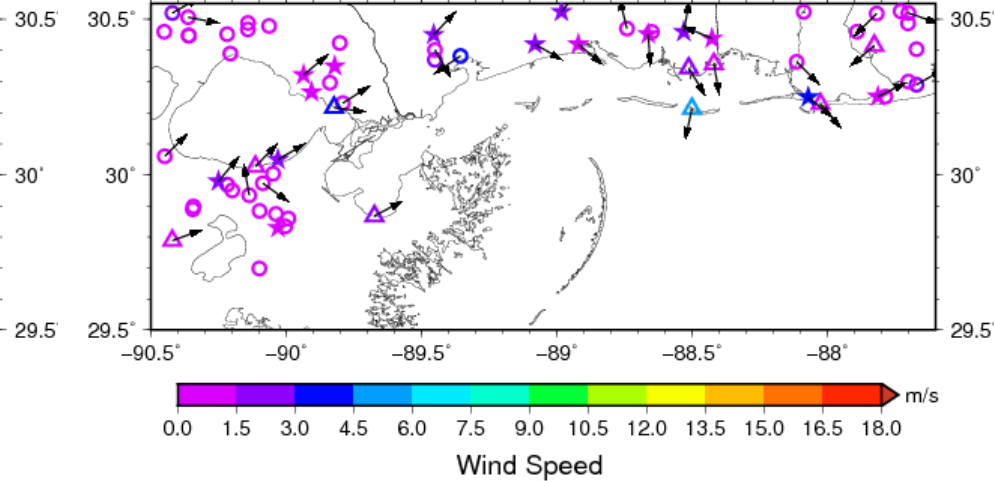

Upcoming CONCORDE activities

- Community workshops with general public, especially commercial fishermen
- Teacher workshops
- Spring cruise for high river season
- Bonnet Carre Spillway opening also being assessed
- Results presents at GOMRI conference in early February, Tampa

